

Section 22

Seat Belts, Cabin Comfort and Pitot Tube

Procedures covered in this section:

Install seat belts; fabricate and install radiator collector; connect cabin comfort hoses; install cabin comfort cables and fuel shut-off cable; fabricate and install seat back brace tube; install pitot tube.

Cards used in this section:

| | | | |
|---------------|-------------|-------------|-------------|
| HARDWARE CARD | E32 CARD 1F | E32 CARD 3F | E54 CARD 1F |
| E25 CARD 2F | E32 CARD 2F | E36 CARD 2F | |

Prints used in this section:

E32-2000

Templates used in this section:

E30-2

Tools required for this section:

| | | | |
|-----------------------|---------------------|---------------|--------------|
| Air or electric drill | Hammer | Pop rivet gun | Tape measure |
| Band saw or hacksaw | Mallet | Scissors | Vise |
| Grinder | Metal cutting snips | Screwdrivers | |

Drill bits of the following sizes: 1/8", 1/4", 3/8", 9/16", #40, #19, Uni-bit or step drill

Ratchet with sockets of the following sizes: 5/16", 3/8", 7/16", 1/2"

Wrenches of the following sizes: 5/16", 3/8", 7/16", 1/2", 9/16", 7/8"

Notes:

1. PUSH/PULL CABLES: The cabin comfort and fuel valve push/pull cables can be shortened if desired for better routing. To do this, pull the inner cable into the housing and trim off the excess housing. Then extend the cable, determine the correct length, and trim the cable. **IMPORTANT: THIS APPLIES ONLY TO THE CABIN COMFORT AND FUEL VALVE CABLES. DO NOT SHORTEN ANY OTHER CABLES.**

SEAT BELTS

Photo #1

Parts as received from RotorWay International for the seat belts.



Photo #2

Wrap both shoulder straps around the 1-1/2" vertical airframe tube, just above the drive mount tubes. Use only one buckle for both straps on each side. Keep the buckle location to the inside of the airframe to prevent any interference between the buckle and the fuel tanks.



Photo #3

Drill a 1/4" bolt hole in approximately the area shown, and bolt the outboard lap belt to the airframe on the passenger side. Use 1/4 x 2-1/4 bolts, part number E00-2413, found on E32 CARD 3F.



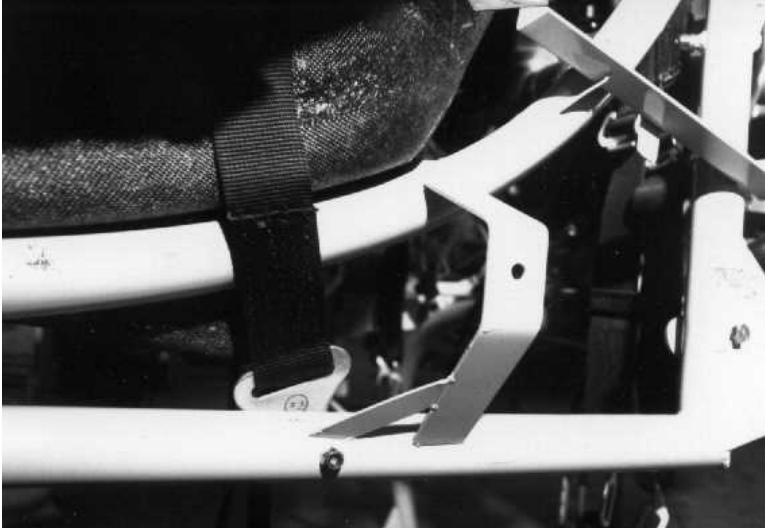

Photo #4

On the pilot's side, drill a 1/4" hole in approximately the same location. Bolt the belt to the airframe.



Photo #5

Cut slots in the back and bottom of the seat bulkhead where each of the seat belts come through.



Photo #6

Place the seat bulkhead on the airframe. Bolt the pilot and passenger inboard lap belts to the airframe cross tube, using the same bolts that hold the back of the seat in place (3/16 x 1-5/8, part number E00-2308 found on E32 CARD 3F).

IMPORTANT: Make sure there is no interference between the buckles and the collective handle when raised.

CABIN COMFORT

Photo #7

Using template E30-2, cut out the radiator collector. If you do not have a sheet metal brake, you can use a vise and wood as shown to bend the part.



Photo #8

Another view of bending the collector in a vise.



Photo #9

Bend the sides of the radiator collector first.

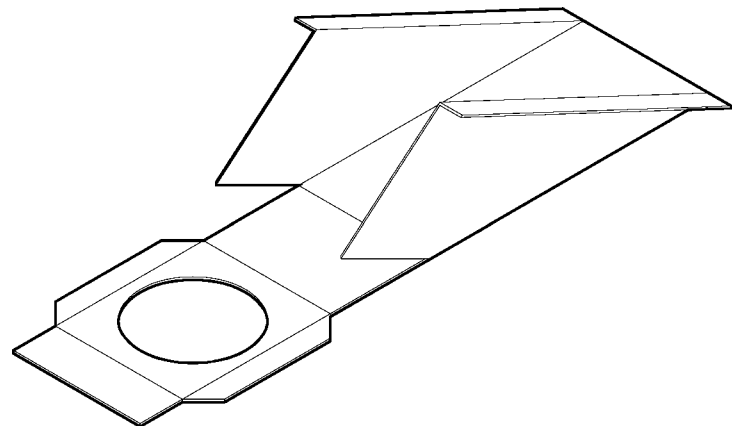

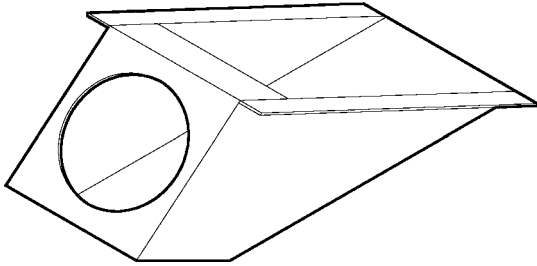

Photo #10

Shape and bend the end.

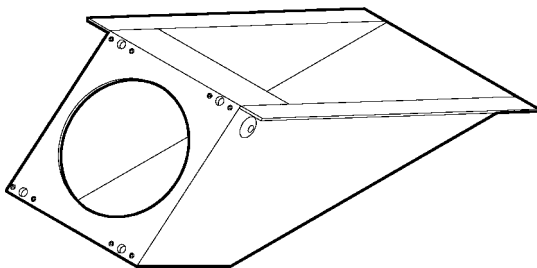

Photo #11

Drill and install the pop rivets to hold the collector's shape. Install four 8-32 nut plates (one in each corner) as shown to fasten the collector to the fiberglass fan shroud.

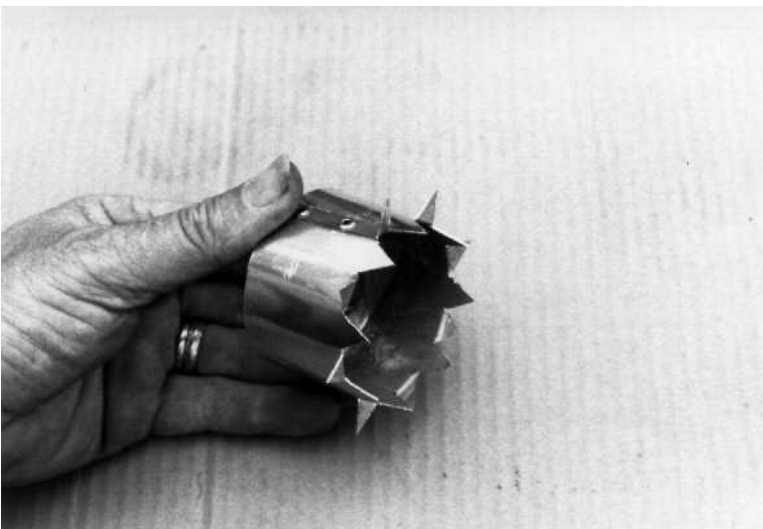

Photo #12

Use the template to cut out and shape the collector collar, bending every other ear at a 90 degree angle as shown.

Photo #13

Insert the collar in the hole of the radiator collector and bend the other ears 90 degrees on the inside of the collector. Trim any points of the ears that extend beyond the edges.

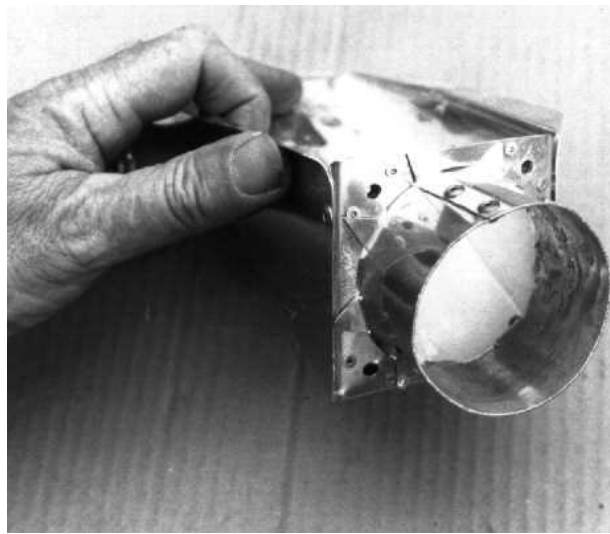

Photo #14

Glue a 2" long strip of 1/4" channel rubber molding to the edge of the collector as shown. Also glue foam weather stripping to the edges of the collector where it will contact the radiator.

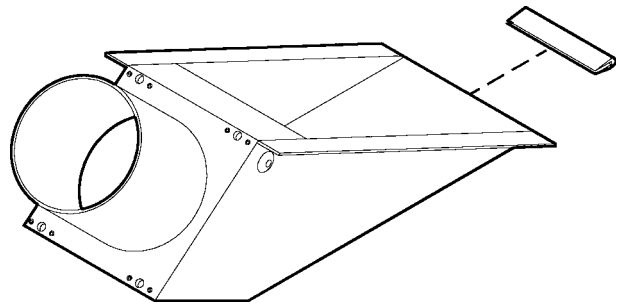
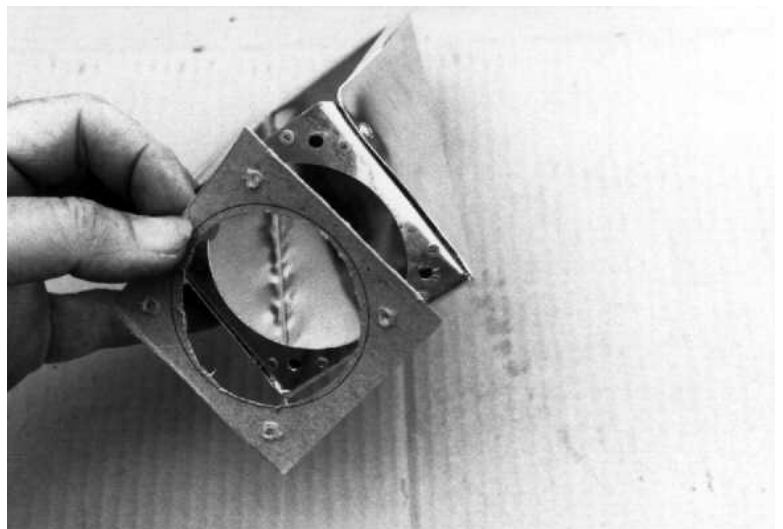

Photo #15

Make a cardboard template of the end of the collector.



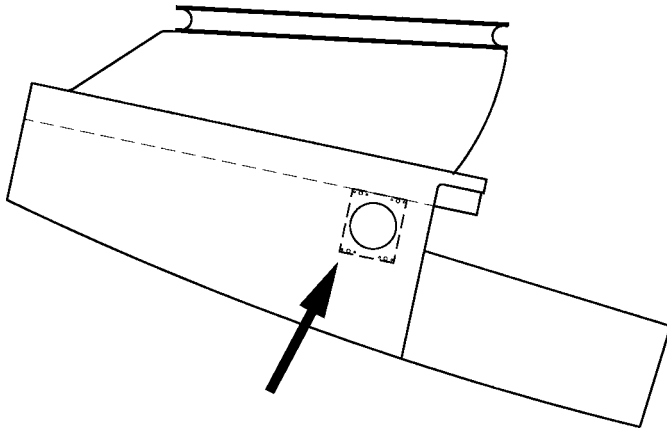

Photo #16

Use the cardboard template to lay out and drill the holes on the outside of the shroud. Mount the collector on the inside of the shroud on the passenger's side, approximately 1-1/2 inches behind the front of the shroud.

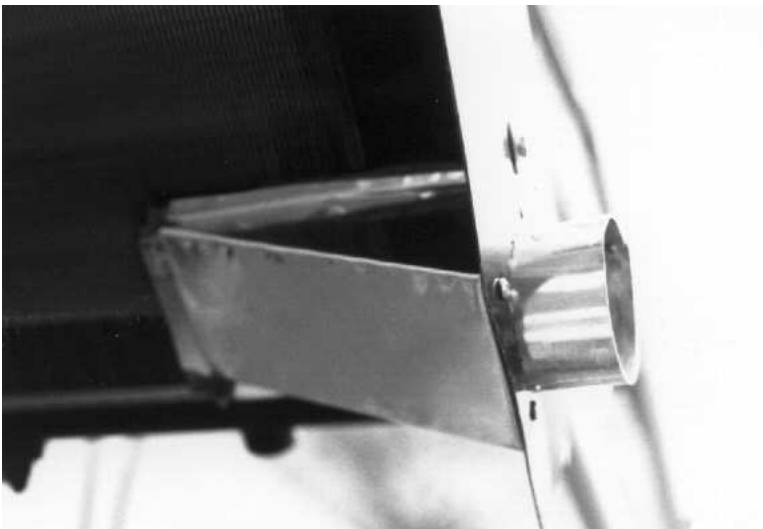

Photo #17

The collector shown mounted to the shroud and secured with four 8-32 screws.

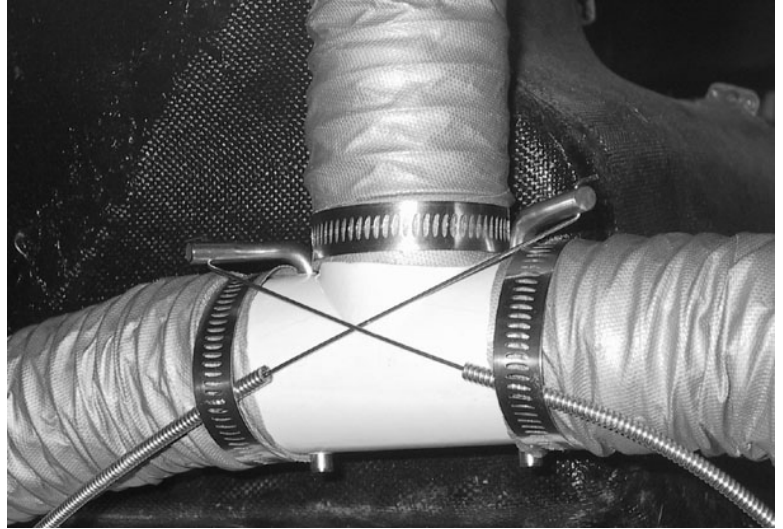

Photo #18

Mount the cabin comfort cables and fuel shut off cable on the console as shown. Locate holes so that the cables do not contact the landing gear tube underneath. Route the cables so that they do not interfere with any moving parts. Attach the other end of the fuel shut off cable to the fuel valve/filter assembly as shown in Section 20, Photo 25.

Photo #19

Connect the hoses and control cables to the three way collector. The hose at left is from the radiator collector. The hose at right is from the fresh air scoop. The top hose is the outlet to the cabin comfort plenum on the underside of the instrument pod. Use care not to damage the collector by over-tightening the clamps.



SEAT BACK BRACE TUBE

Photo #20

The seat back brace tube serves as a stiffener and also helps retain the cyclic control push/pull cables away from moving parts. Locate the brace to span across the channel in the back of the seat bulkhead where it will most effectively retain the cables. Cut the tube to length, flatten the ends, and rivet two 8-32 nut plates to the flats.

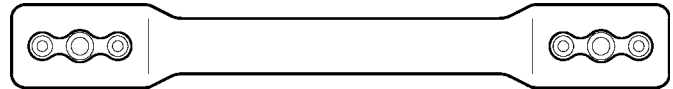
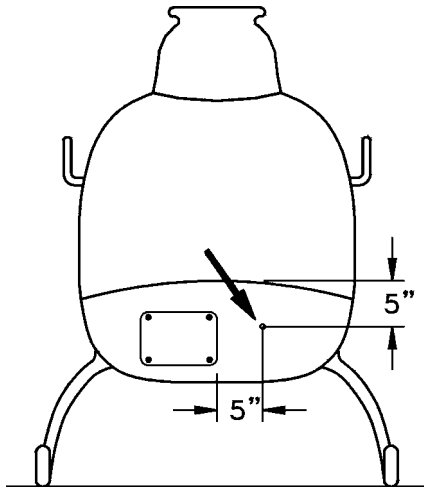

Photo #21

Mount the seat back brace tube to the back of the seat bulkhead with two 8-32 screws.





PITOT TUBE

Photo #22

Drill a 1/4" hole in the tub at a point approximately 5" below the windscreen and 5" to the pilot's side of the front inspection panel. (The exact location is not critical.)

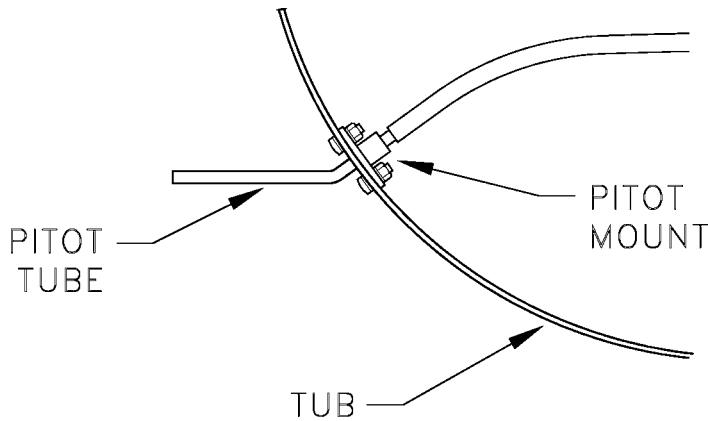

Photo #23

Sand the pitot tube and the mount where they will be joined together, and clean both parts with acetone. Using blade glue, bond the tube in the mount. The tube should extend forward 6". After the glue is set, insert the pitot tube through the hole in the tub from the inside. Fasten the mount on the inside of the tub using three 6-32 screws, nuts and washers.

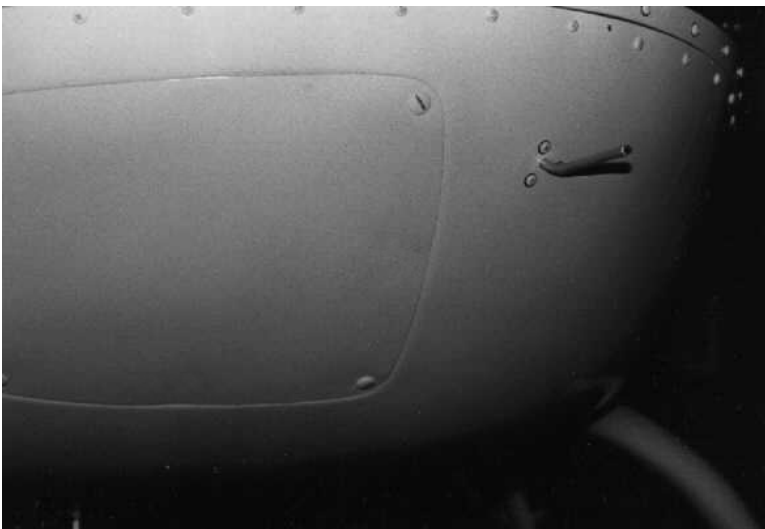

Photo #24

Bend the tube so that it faces straight forward. Route the plastic tubing from the pitot tube to the airspeed indicator.